

NOTE:
Please read all instructions
carefully before using this
product

Table of Contents

Safety Notice

Hardware Identifier

Assembly Instruction

Parts List

Warranty

Ordering Parts

Model
CB-180

Retain This
Manual for
Reference

06-13-06

OWNER'S
MANUAL

IMPEX

COMPETITOR WEIGHT BENCH CB-180

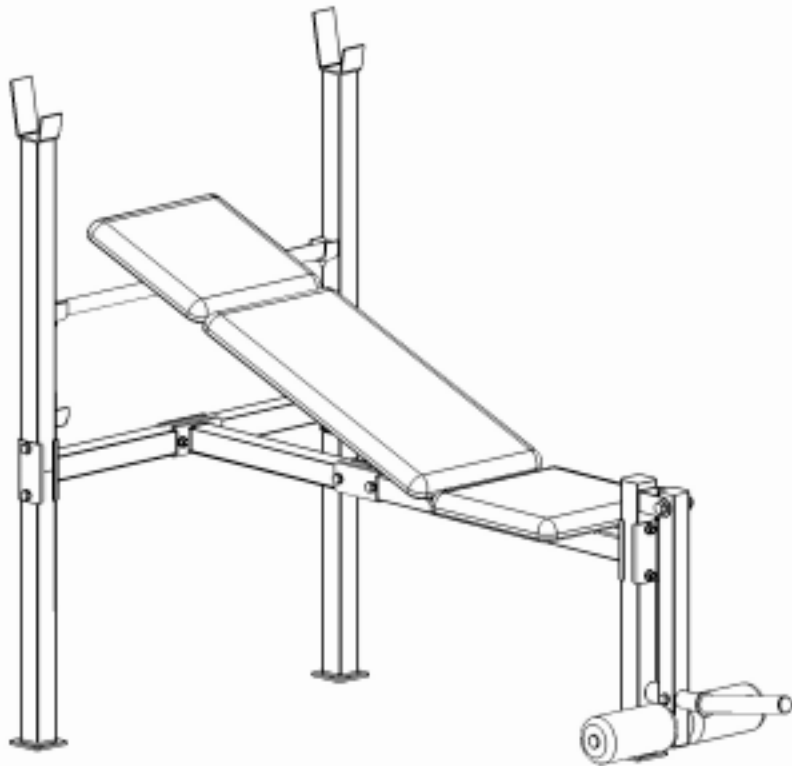

IMPEX INC.

14777 DON JULIAN RD., CITY OF INDUSTRY, CA 91746

Tel: (800) 999-8899 Fax: (626) 961-9966

www.impex-fitness.com

info@impex-fitness.com

TABLE OF CONTENTS

BEFORE YOU BEGIN.....	1
IMPORTANT SAFETY NOTICES.....	2
HARDWARE IDENTIFIER.....	4
ASSEMBLY INSTRUCTIONS.....	5
EXPLODED DIAGRAM.....	9
PARTS LIST.....	10
WARRANTY.....	11
ORDERING PARTS.....	11

BEFORE YOU BEGIN

Thank you for selecting the COMPETITOR CB-180 Weight Bench by IMPEX INC. For your safety and benefit, read this manual carefully before using the machine. As a manufacturer, we are committed to provide you complete customer satisfaction. If you have any questions, or find there are missing or damaged parts, we guarantee you complete satisfaction through direct assistance from our factory. To avoid unnecessary delays, *please call our TOLL-FREE customer service number.* Our Customer Service Agents will provide immediate assistance to you.

Toll-Free Customer Service Number

1-800-999-8899

Mon. - Fri. 9 a.m. - 5 p.m. PST

www.impex-fitness.com

info@impex-fitness.com

IMPORTANT SAFETY NOTICE

PRECAUTIONS

This exercise machine is built for optimum safety. However, certain precautions apply whenever you operate a piece of exercise equipment. Be sure to read the entire manual before you assemble or operate your machine. In particular, note the following safety precautions:

1. **Keep children and pets away from the machine at all times. DO NOT leave children unattended in the same room with the machine.**
2. Only one person at a time should use the machine.
3. If the user experiences dizziness, nausea, chest pain, or any other abnormal symptoms, STOP the workout at once. CONSULT A PHYSICIAN IMMEDIATELY.
4. Position the machine on a clear, leveled surface. DO NOT use the machine near water or outdoors.
5. Keep hands and feet away from all moving parts.
6. Always wear appropriate workout clothing when exercising. DO NOT wear robes or other clothing that could become caught in the machine. Running or aerobic shoes are also required when using the machine.
7. Use the machine only for its intended use as described in this manual. DO NOT use attachments not recommended by the manufacturer.
8. Do not place any sharp object around the machine.
9. Disabled person should not use the machine without a qualified person or physician in attendance.
10. Before using the machine to exercise, always do stretching exercises to properly warm up.
11. Never operate the machine if the machine is not functioning properly.
12. A spotter is recommended during exercise.
13. Maximum user's weight capacity 200 lbs.
14. Maximum weight capacity on Leg Developer 80 lbs.
15. Maximum weight capacity on Uprights 200 lbs.

CARE AND MAINTENANCE

1. Inspect and tighten all parts before using the machine.
2. The machine can be cleaned using a damp cloth and mild non-abrasive detergent. DO NOT use solvents.

WARNING: BEFORE BEGINNING ANY EXERCISE PROGRAM, CONSULT YOUR PHYSICIAN. THIS IS ESPECIALLY IMPORTANT FOR INDIVIDUALS OVER THE AGE OF 35 OR PERSONS WITH PRE-EXISTING HEALTH PROBLEMS. READ ALL INSTRUCTIONS BEFORE USING ANY FITNESS EQUIPMENT. IMPEX INC. ASSUMES NO RESPONSIBILITY FOR PERSONAL INJURY OR PROPERTY DAMAGE SUSTAINED BY OR THROUGH THE USE OF THIS PRODUCT. SAVE THESE INSTRUCTIONS.

WARNING LABEL REPLACEMENT

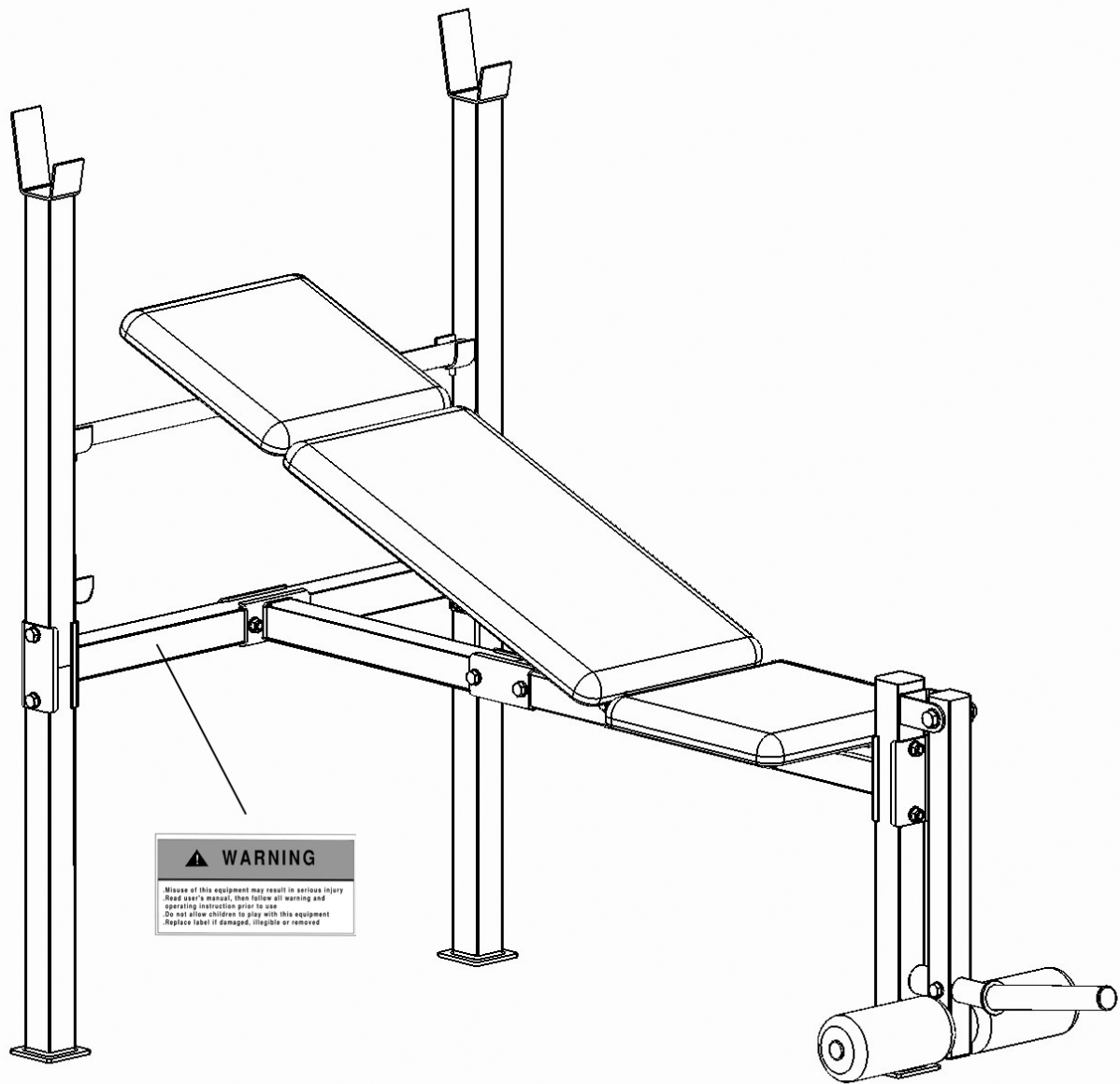

The Warning Label shown here has been placed on the Cross Brace. If the label is missing or illegible, please call customer service at 1-800-999-8899 for replacement. Apply the label in location shown.

HARDWARE PACK



#17 M10 x 6 7/8" Axle (Qty 1)

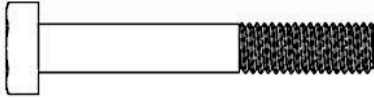

#18 M8 x 2 1/8" Hex Bolt (Qty 10)

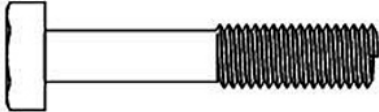

#19 M10 x 2 1/8" Hex Bolt (Qty 1)

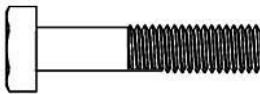

#20 M6x 1 3/8" Hex Bolt (Qty 8)

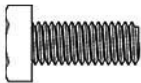

#21 M6 x 5/8" Hex Bolt (Qty 2)

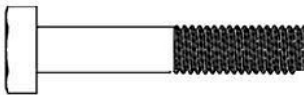

#22 M8 x 1 3/4" Hex Bolt (Qty 1)

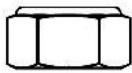

#26 M8 Aircraft Nut
(Qty 11)



#27 M10 Aircraft Nut
(Qty 3)

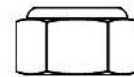

#28 M6 Aircraft Nut
(Qty 2)

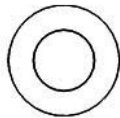

#23 ϕ 3/4" Washer
(Qty 4)

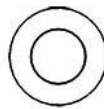

#24 ϕ 5/8" Washer
(Qty 22)



#25 ϕ 1/2" Washer
(Qty 12)

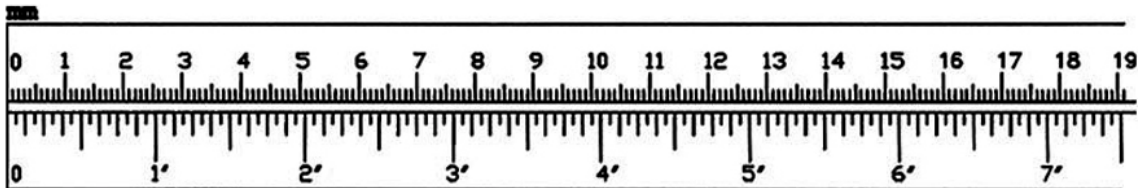

ASSEMBLY INSTRUCTION

Tools Required Assembling the Machine: Two Adjustable Wrenches.

NOTE: It is strongly recommended two or more people assembling this machine to avoid possible injury.

STEP 1 (See Diagram 1)

- A.) Attach the Left & Right Upright Beams (#1 & 2) onto the Lower Upright Beams (#3).
- B.) Connect the Left & Right Upright Beams by a Cross Brace (#4) in the Mid-span.
Secure them with two M8 x 2 1/8" Hex Bolts (#18), one Bracket (#16), four \varnothing 5/8" Washers (#24), and two M8 Aircraft Nuts (#26) on each end of the Cross Brace.
- C.) Place the Backrest Adjustment Bar (#13) onto selected slot on the Upright Beams to obtain desired incline of Backrest.

DIAGRAM 1

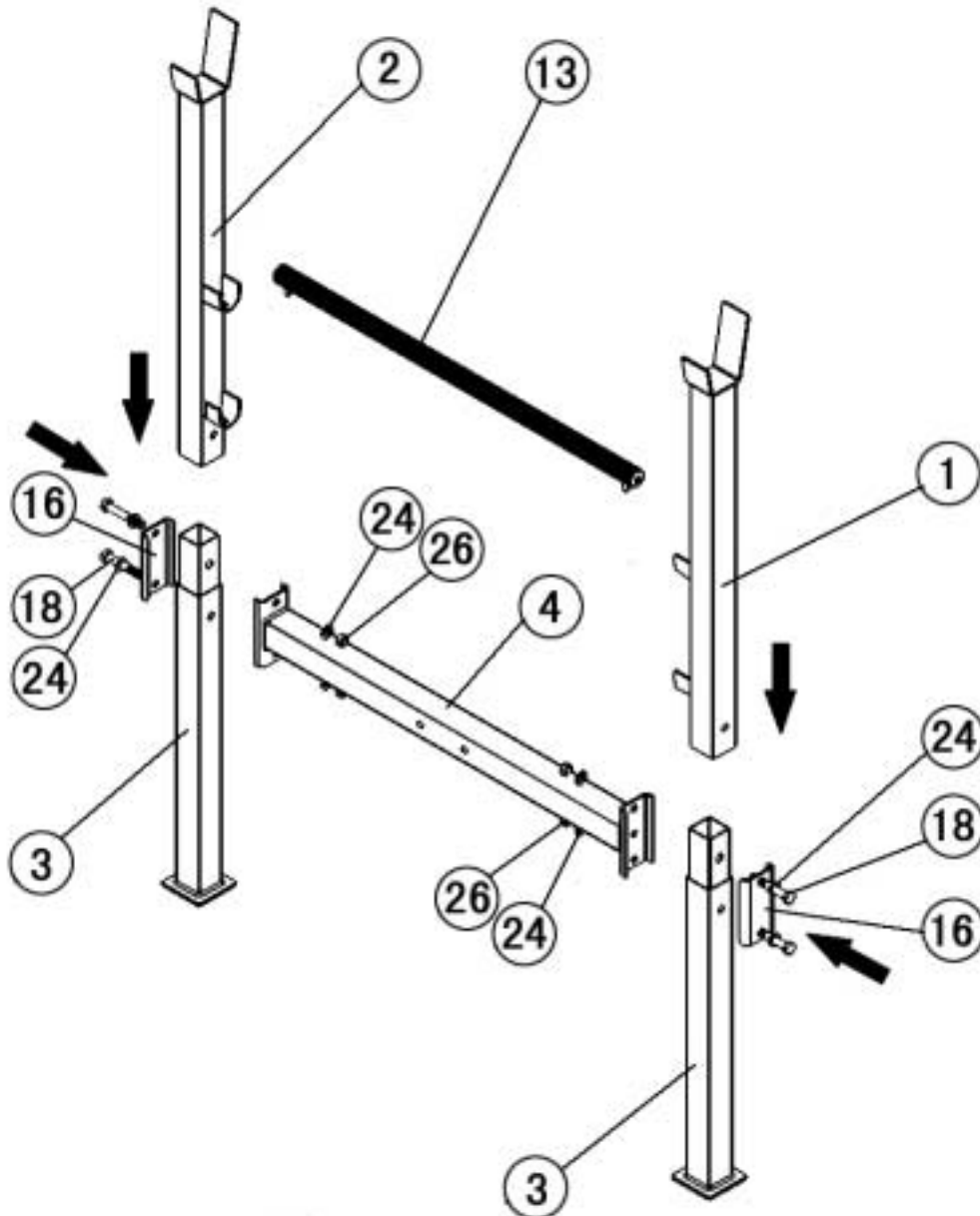

STEP 2 (See Diagram 2)

- A.) Insert the Main Support Frame (#5) into the Seat Support Frame (#6). Secure them with two M8 x 2 1/8" Hex Bolts (#18), two Brackets (#16), four Ø 5/8" Washers (#24), and two M8 Aircraft Nuts (#26).
- B.) Attach the Main Support Frame (#5) to the Cross Brace (#4). Secure it with two M8 X 2 1/8" Hex Bolts (#18), one Bracket (#16), four Ø 5/8" Washers (#24), and two M8 Aircraft Nuts (#26).
- C.) Attach the Seat Support Frame (#6) to the Leg Developer Holder (#7). Secure it with two M8 x 2 1/8" Hex Bolts (#18), one Bracket (#16), four Ø 5/8" Washers (#24), and two M8 Aircraft Nuts (#26).
- D.) Place the Seat Pad (#12) onto the Seat Support Frame (#6). Secure it with two M6 x 5/8" Hex Bolts (#21) and two Ø 1/2" Washers (#25).

DIAGRAM 2

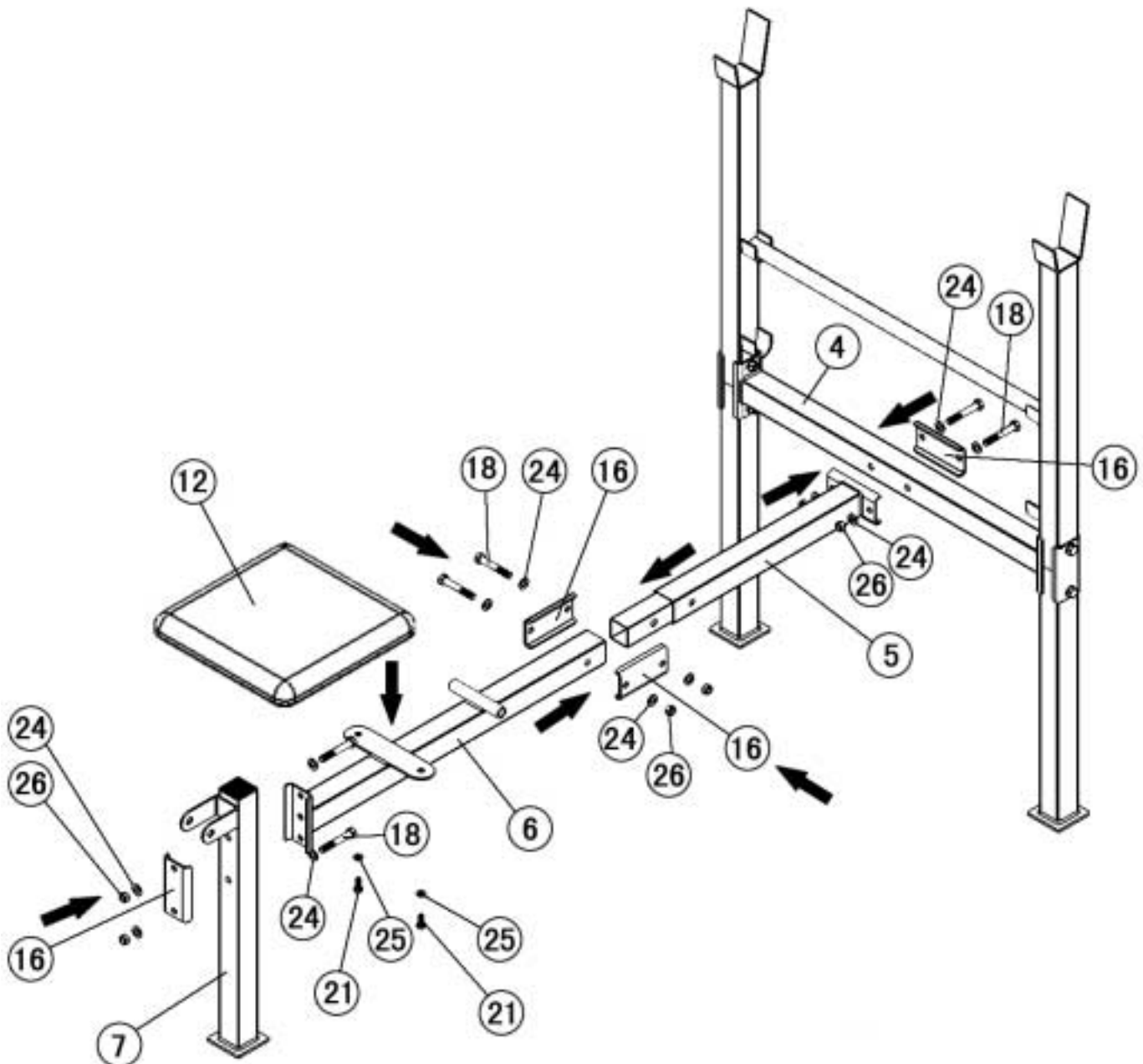

STEP 3 (See Diagram 3)

- A.) Insert the two Upper Backrest Supports (#8) into two Lower Backrest Supports (#9). Secure them with two M6 x 1 3/8" Hex Bolts (#20), four Ø 1/2" Washers (#25), and two M6 Aircraft Nuts (#28).
- B.) Attach the side-holes on the Lower Backrest Supports (#9) to each end of the pivot on the Seat Support Frame (#6). Align the holes and insert a M10 x 6 7/8" Axle (#17) through the holes. Secure it with two Ø 3/4" Washers (#23) and M10 Aircraft Nuts (#27). Do not over tighten the Nuts. Make sure the Backrest Supports are able to swivel.
- C.) Place the Lower Backrest Board (#10) onto the Backrest Supports. Secure it with four M6 x 1 3/8" Hex Bolts (#20) and Ø 1/2" Washers (#25).
- D.) Place the Upper Backrest Board (#11) onto the Backrest Supports. Secure it with two M6 x 1 3/8" Hex Bolts (#20) and Ø 1/2" Washers (#25).

DIAGRAM 3

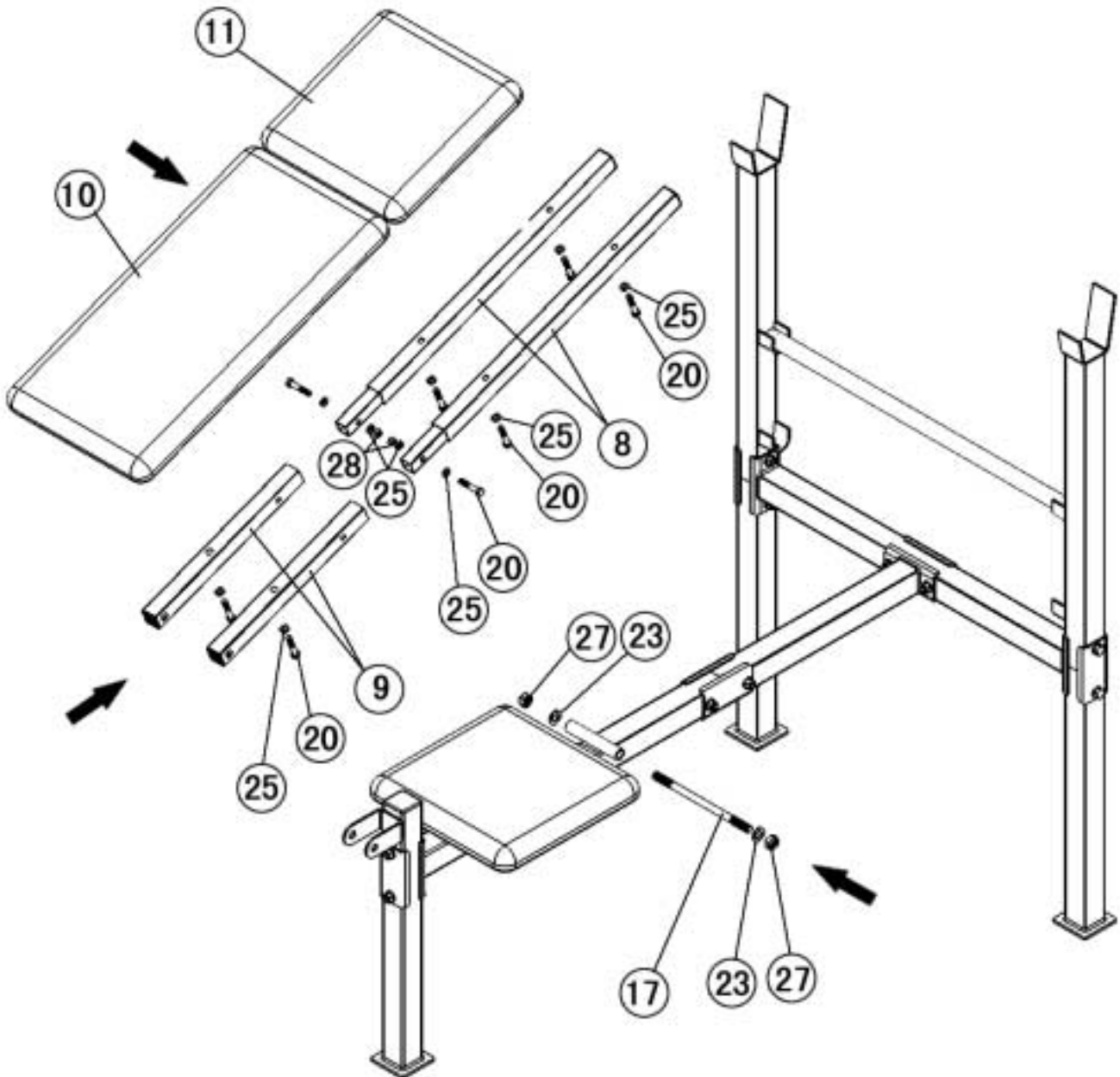

STEP 4 (See Diagram 4)

- A.) Attach the Leg Developer (#29) to the Leg Developer Holder (#7). Secure it with one M10 x 2 1/8" Hex Bolt (#19), two Ø 3/4" Washers (#23), and one M10 Aircraft Nut (#27). Do not over tighten the Nut and Bolt. Make sure the Leg Developer is able to swivel.
- B.) Insert the Weight Post (#31) into the Leg Developer. Secure it with one M8 x 1 3/4" Hex Bolt (#22), two Ø 5/8" Washers (#24), and one M8 Aircraft Nut (#26).
- C.) Insert the Foam Tube (#30) halfway through the holes on the Leg Developer. Attach two Foam Rolls (#32) onto the Tube from both ends.

DIAGRAM 4

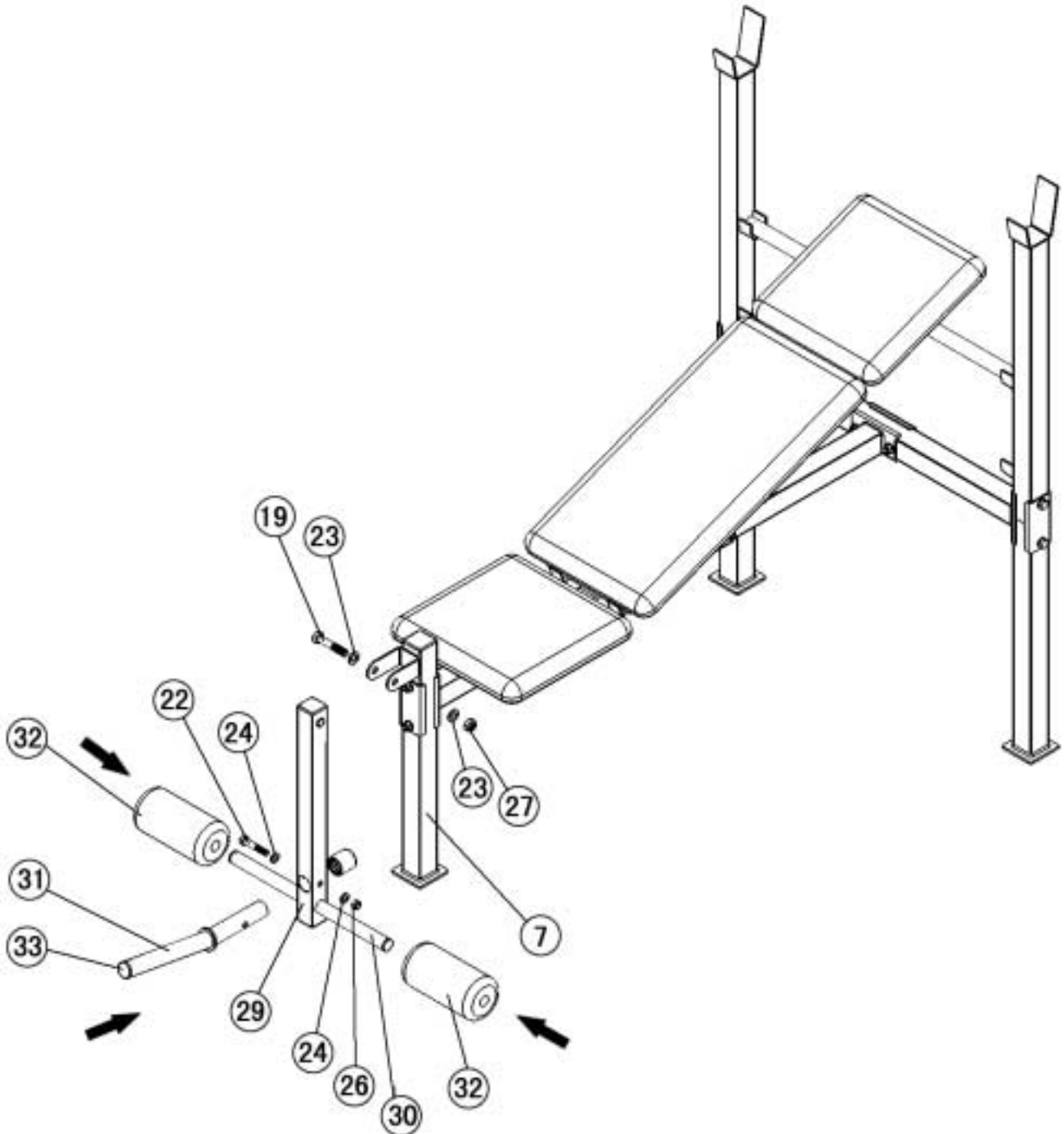

EXPLODED DIAGRAM

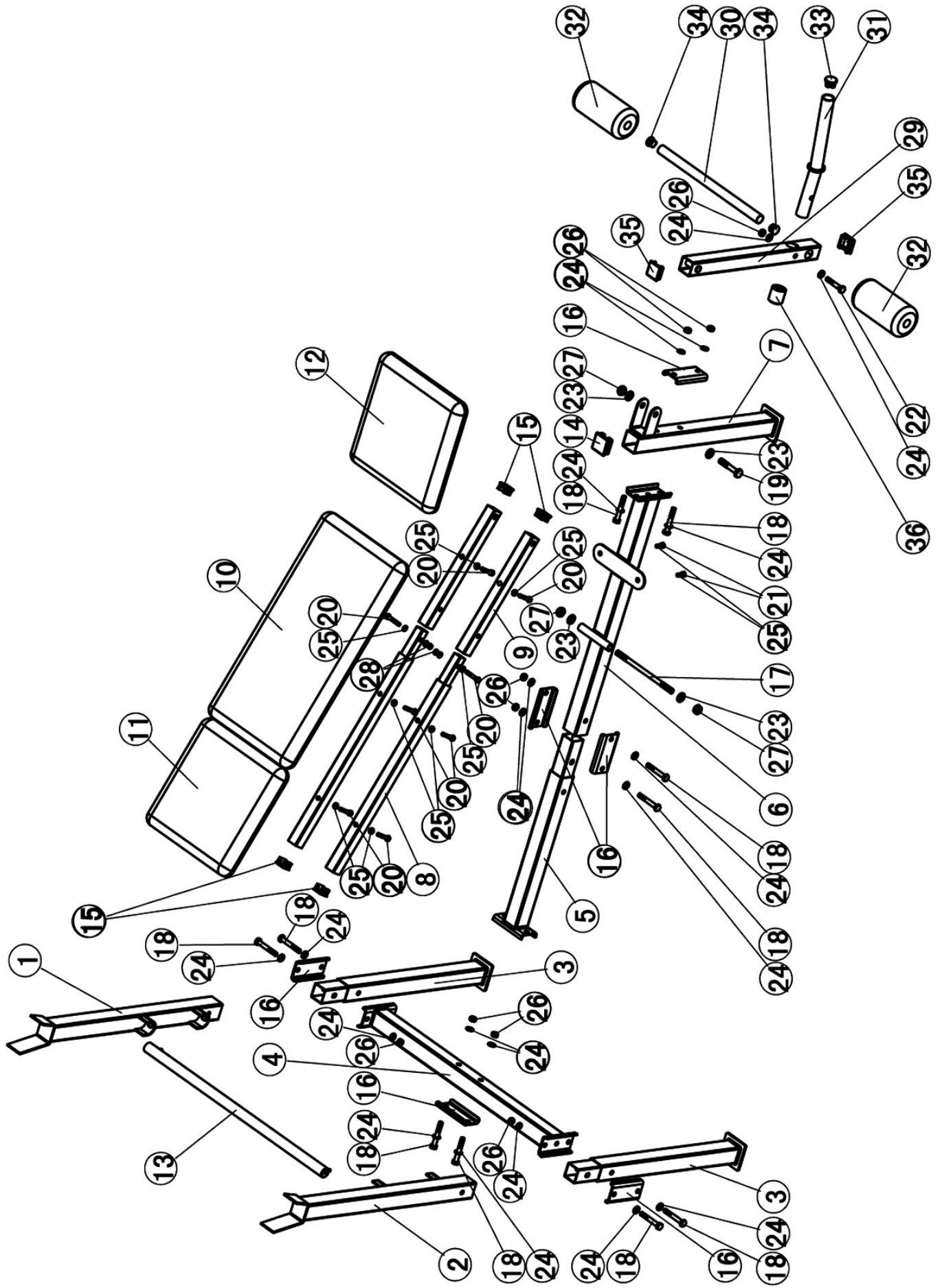

PARTS LIST

<u>KEY NO.</u>	<u>DESCRIPTION</u>	<u>QUANTITY</u>
1	Left Upright Beam	1
2	Right Upright Beam	1
3	Lower Upright Beam	2
4	Cross Brace	1
5	Main Support Frame	1
6	Seat Support Frame	1
7	Leg Developer Holder	1
8	Upper Backrest Support	2
9	Lower Backrest Support	2
10	Lower Backrest Board	1
11	Upper Backrest Board	1
12	Seat Pad	1
13	Backrest Adjustment Bar	1
14	1 ½" Square End Cap	1
15	1" Square End Cap	4
16	Bracket	6
17	M10 x 6 7/8" Axle	1
18	M8 x 2 1/8" Hex Bolt	10
19	M10 x 2 1/8" Hex Bolt	1
20	M6 x 1 3/8" Hex Bolt	8
21	M6 x 5/8" Hex Bolt	2
22	M8 x 1 ¾" Hex Bolt	1
23	Ø ¾" Washer	4
24	Ø 5/8" Washer	22
25	Ø ½" Washer	12
26	M8 Aircraft Nut	11
27	M10 Aircraft Nut	3
28	M6 Aircraft Nut	2
29	Leg Developer	1
30	Foam Tube	1
31	Weight Post	1
32	Foam Roll	2
33	Ø 1" End Cap	1
34	Ø ¾" End Cap	2
35	1 ¼" Square End Cap	2
36	Rubber Bumper	1

IMPEX INC.

LIMITED WARRANTY

IMPEX Inc. ("IMPEX") warrants this product to be free from defects in workmanship and material, under normal use and service conditions, for a period of two years on the Frame from the date of purchase. This warranty extends only to the original purchaser. IMPEX's obligation under this Warranty is limited to replacing or repairing, at IMPEX's option.

All returns must be pre-authorized by IMPEX. Pre-authorization may be obtained by calling IMPEX Customer Service Department at 1-800-999-8899. All freights for products return to IMPEX must be prepaid by the customer. This warranty does not extend to any product or damage to a product caused by or attributable to freight damage, abuse, misuse, improper or abnormal usage or repairs not provided by an IMPEX authorized service center or for products used for commercial or rental purposes. No other warranty beyond that specifically set forth above is authorized by IMPEX.

IMPEX is not responsible or liable for indirect, special or consequential damages arising out of or in connection with the use or performance of the product or other damages with respect to any economic loss, loss of property, loss of revenues or profits, loss of enjoyments or use, costs of removal, installation or other consequential damages or whatsoever natures. Some states do not allow the exclusion or limitation of incidental or consequential damages. Accordingly, the above limitation may not apply to you.

The warranty extended hereunder is in lieu of any and all other warranties and any implied warranties of merchantability or fitness for a particular purpose is limited in its scope and duration to the terms set forth herein. Some states do not allow limitations on how long an implied warranty lasts. Accordingly, the above limitation may not apply to you.

This warranty gives you specific legal right. You may also have other rights which vary from state to state. Register on-line www.impex-fitness.com

IMPEX INC.
14777 Don Julian
City of Industry, CA 91746

ORDERING REPLACEMENT PARTS

Replacement parts can be ordered by calling our Customer Service Department toll-free at **1-800-999-8899** during our regular business hours: Monday through Friday, 9 am until 5 pm Pacific standard time.
info@impex-fitness.com

When ordering replacement parts, always give the following information.

1. Model
2. Description of Parts
3. Part Number
4. Date of Purchase