

NOTE:
Please read all instructions
carefully before using this
product

Table of Contents

Safety Notice

Hardware Identifier

Assembly Instruction

Parts List

Warranty

Ordering Parts

Model
PHC-1955

Retain This
Manual for
Reference

06-28-03

OWNER'S
MANUAL

IMPEx
FITNESS PRODUCTS

POWERHOUSE OLYMPIC BENCH

PHC 1955

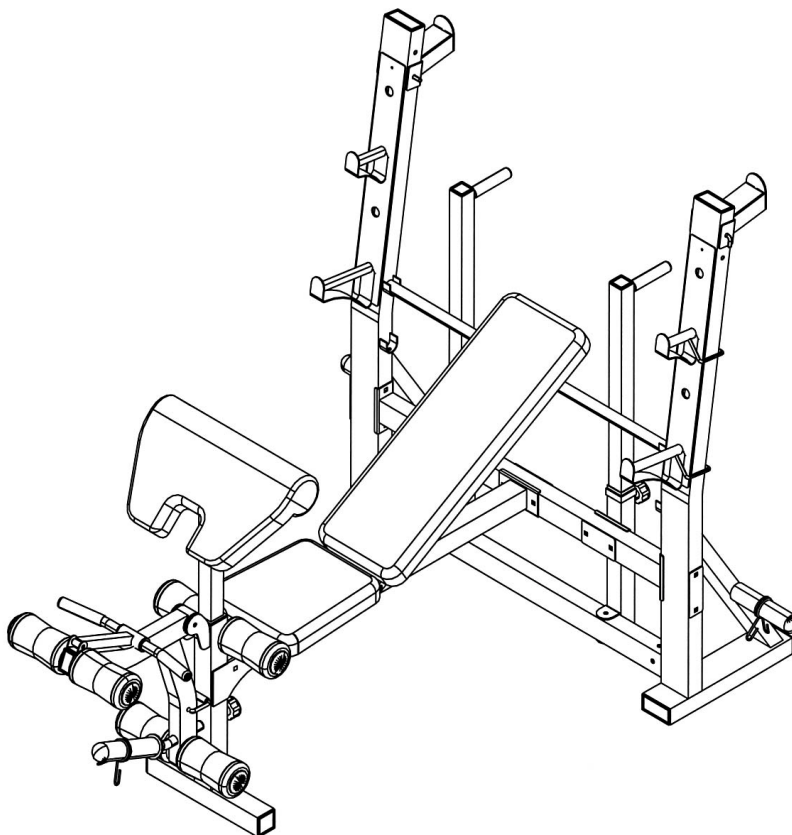

IMPEx FITNESS PRODUCTS

14777 DON JULIAN RD., CITY OF INDUSTRY, CA 91746

Tel: (800) 999-8899 Fax: (626) 961-9966

www.impex-fitness.com

info@impex-fitness.com

TABLE OF CONTENTS

BEFORE YOU BEGIN.....	1
IMPORTANT SAFETY NOTICES.....	2
HARDWARE PACK.....	3
ASSEMBLY INSTRUCTIONS.....	5
EXPLODED DIAGRAM.....	10
PARTS LIST.....	11
WARRANTY.....	12
ORDERING PARTS.....	12

BEFORE YOU BEGIN

Thank you for selecting the POWERHOUSE PHC-1955 WEIGHT BENCH by IMPEX FITNESS PRODUCTS. For your safety and benefit, read this manual carefully before using the machine. As a manufacturer, we are committed to provide you complete customer satisfaction. If you have any questions, or find there are missing or damaged parts, we guarantee you complete satisfaction through direct assistance from our factory. To avoid unnecessary delays, *please call our TOOL-FREE customer service number.* Our Customer Service Agents will provide immediate assistance to you.

Toll-Free Customer Service Number

1-800-999-8899

Mon. – Fri. 9 a.m. – 5 p.m. PST

www.impex-fitness.com

info@impex-fitness.com

IMPORTANT SAFETY NOTICE

PRECAUTIONS

This exercise machine is built for optimum safety. However, certain precautions apply whenever you operate a piece of exercise equipment. Be sure to read the entire manual before you assemble or operate your machine. In particular, note the following safety precautions:

1. **Keep children and pets away from the machine at all times. DO NOT leave children unattended in the same room with the machine.**
2. Only one person at a time should use the machine.
3. If the user experiences dizziness, nausea, chest pain, or any other abnormal symptoms, STOP the workout at once. CONSULT A PHYSICIAN IMMEDIATELY.
4. Position the machine on a clear, leveled surface. DO NOT use the machine near water or outdoors.
5. Keep hands away from all moving parts.
6. Always wear appropriate workout clothing when exercising. DO NOT wear robes or other clothing that could become caught in the machine. Running or aerobic shoes are also required when using the machine.
7. Use the machine only for its intended use as described in this manual. DO NOT use attachments not recommended by the manufacturer.
8. Do not place any sharp object around the machine.
9. Disabled person should not use the machine without a qualified person or physician in attendance.
10. Before using the machine to exercise, always do stretching exercises to properly warm up.
11. Never operate the machine if the machine is not functioning properly.
12. A spotter is recommended during exercise.

WARNING: BEFORE BEGINNING ANY EXERCISE PROGRAM, CONSULT YOUR PHYSICIAN. THIS IS ESPECIALLY IMPORTANT FOR INDIVIDUALS OVER THE AGE OF 35 OR PERSONS WITH PRE-EXISTING HEALTH PROBLEMS. READ ALL INSTRUCTIONS BEFORE USING ANY FITNESS EQUIPMENT. IMPEX INC. ASSUMES NO RESPONSIBILITY FOR PERSONAL INJURY OR PROPERTY DAMAGE SUSTAINED BY OR THROUGH THE USE OF THIS PRODUCT.

SAVE THESE INSTRUCTIONS.

HARDWARE PACK

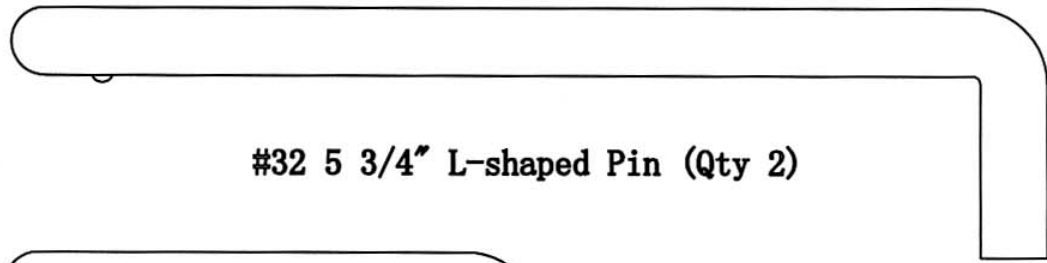

#32 5 3/4" L-shaped Pin (Qty 2)

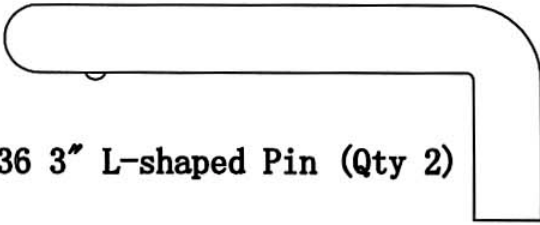

#36 3" L-shaped Pin (Qty 2)

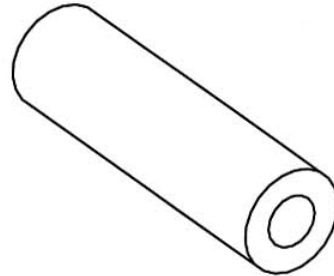

#41 Axle (Qty 1)

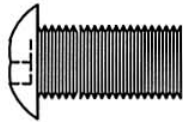

#72 M10 x 3/4" Allen Bolt
(Qty 2)

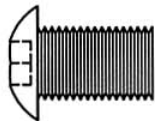

#60 M10 x 5/8" Allen Bolt
(Qty 11)

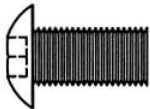

#55 M8 x 5/8" Allen Bolt
(Qty 2)

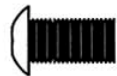

#67 M6 x 1/2" Philips Screw
(Qty 1)

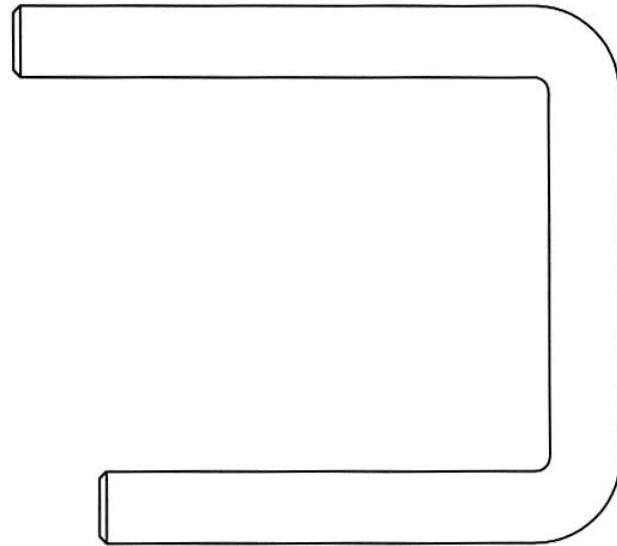

#70 U-shaped Lock Pin (Qty 1)

mm

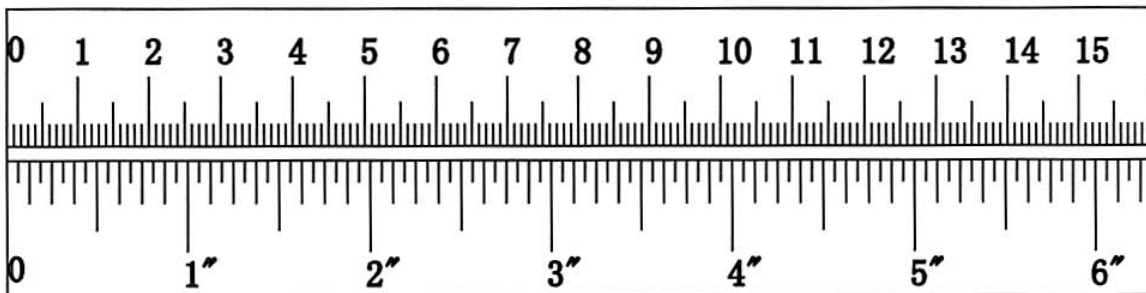

HARDWARE PACK

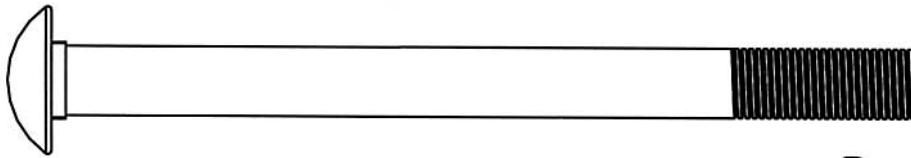

#56 M10 x 5 3/4" Carriage Bolt (Qty 4)

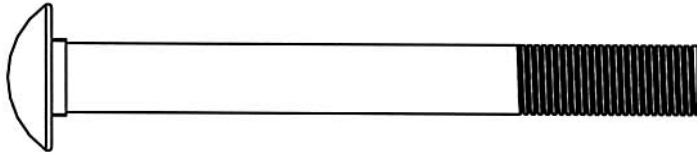

#58 M10 x 3 1/2" Carriage Bolt (Qty 2)

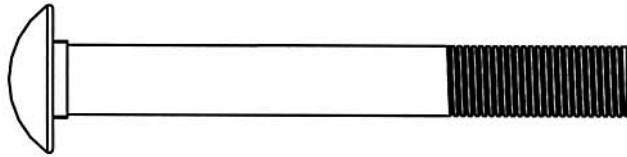

#57 M10 x 3 1/8" Carriage Bolt (Qty 3)

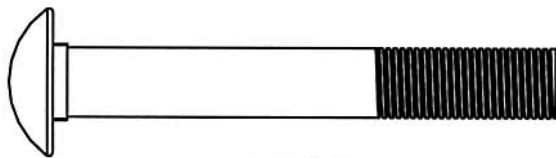

#59 M10 x 2 3/4" Carriage Bolt (Qty 6)

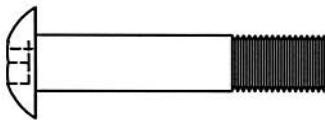

#54 M8 x 1 5/8" Allen Bolt (Qty 8)

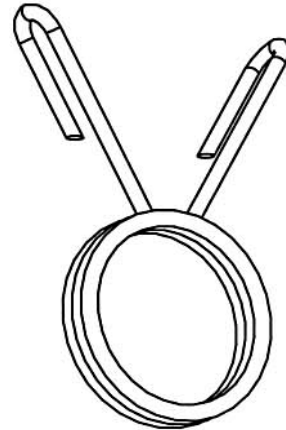

#40 Spring Clip (Qty 3)



#63 M10 Aircraft Nut (Qty 15)

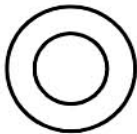

#61 Ø 3/4" Washer (Qty 28)

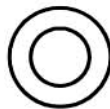

#62 Ø 5/8" Washer (Qty 10)

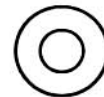

#69 Ø 1/2" Spacer (Qty 1)

mm

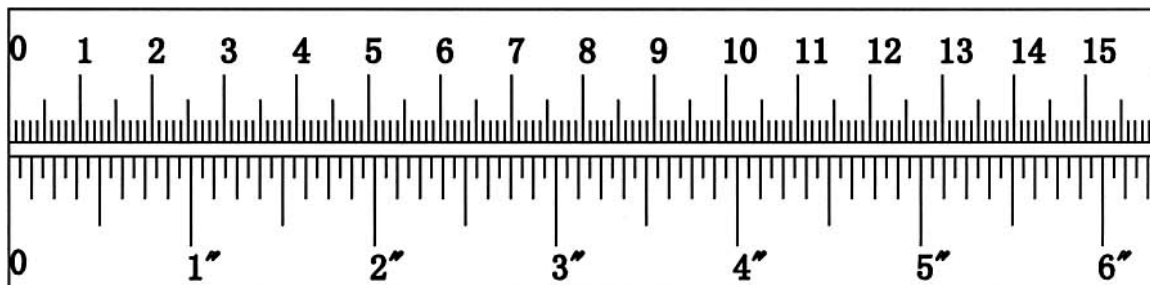

ASSEMBLY INSTRUCTION

Tools Required Assembling the Machine: Two Adjustable Wrenches, two Allen Wrenches, and one Philips Screwdriver.

NOTE: It is strongly recommended this machine to be assembled by two or more people to avoid possible injury.

STEP 1 (See Diagram 1)

- A.) Connect the Left & Right Upright Beams (#2 &3) by the Upper & Lower Cross Braces (#5 &6) in the mid-span.
- B.) Secure each end of the Lower Cross Brace (#6) with three M10 x 5/8" Allen Bolts (#60) and \varnothing 3/4" Washers (#61). NOTE: Do not tighten the Nuts and Bolts yet.
- C.) Secure each end of the Upper Cross Brace (#5) with two M10 x 5 3/4" Carriage Bolts (#56), one 5 1/2" x 2" Bracket (#34), two \varnothing 3/4" Washers (#61), and two M10 Aircraft Nuts (#63).
- D.) Attach the brackets on the Dip Handle Base (#10) to the holes on the Upper & Lower Cross Braces. Secure the Dip Handle Base to the Lower Cross Brace with one M10 x 3 1/2" Carriage Bolt (#58), \varnothing 3/4" Washer (#61), and M10 Aircraft Nut (#63). Secure the Dip Handle Base to the Upper Cross Brace with two M10 x 2 3/4" Carriage Bolts (#59), one 4 3/4" x 2 3/4" Bracket (#27), two \varnothing 3/4" Washers (#61), and two M10 Aircraft Nuts (#63). Repeat the same step to install the other Dip Handle Base.
- E.) Securely tighten all Nuts and Bolts previously installed.
- F.) Insert the two Dip Stands (#11) into the top openings on the Dip Handle Bases. Use M10 Lock Knobs (#37) to secure the Dip Stands.
- G.) Attach the two Squat Bar Catches (#12) to the back of the Upright Beams. Secure each Catch with a 5 3/4" L-shaped Pin (#32).
- H.) Insert a Weight Post (#17) into the hole on the bottom of the Upright Beam. Secure it with one M10 x 3/4" Allen Bolt (#72) and \varnothing 3/4" Washer (#61). Slide an Olympic Sleeve (#39) onto the Post. Attach a Spring Clip (#40) to the Olympic Sleeve. Repeat the same procedure for the other side.
- I.) Insert Left & Right Bar Holders (#18 &19), Right & Left Safety Catch (#20 & 21) into the selected holes on the Upright Beams (#2 & 3).
- J.) Place the Backrest Adjustment Bar (#8) onto the selected slot on the Upright Beams to hold the desired incline position.

DIAGRAM 1

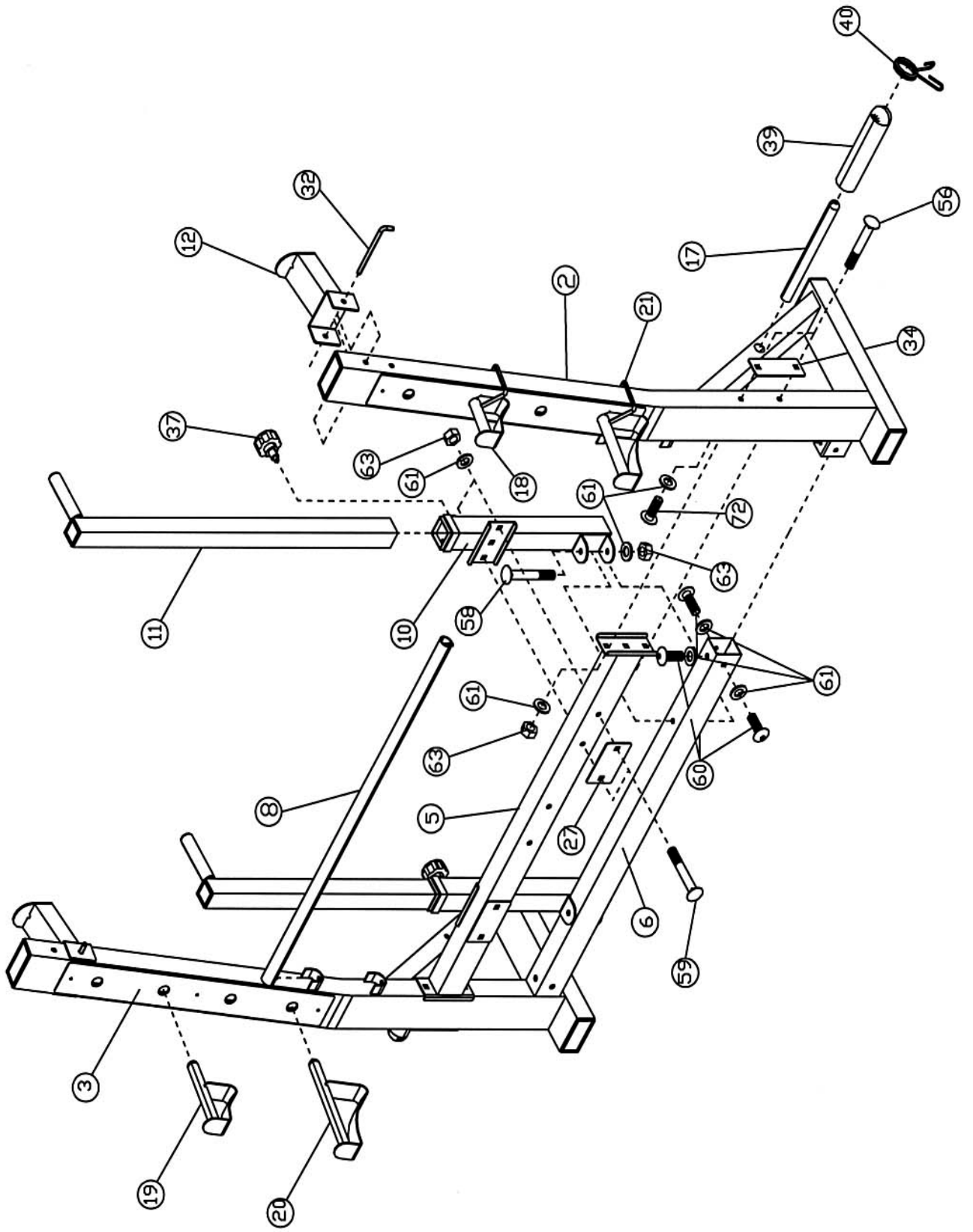

STEP 2 (See Diagram 2)

- A.) Slide the Sliding Block (#7) onto the Main Seat Support (#4). Thread a M12 Lock Knob (#38) into the selected hole on the Main Seat Support to hold the Sliding Block in position.
- B.) Attach the Leg Developer Holder (#1) to the Front Stabilizer (#23). Secure it with three M10 x 5/8" Allen Bolts (#60) and \varnothing 3/4" Washers (#61).
- C.) Attach the Main Seat Support (#4) to the Leg Developer Holder (#1). Secure it with three M10 x 3 1/8" Carriage Bolts (#57), \varnothing 3/4" Washers (#61) and M10 Aircraft Nuts (#63). Thread a M12 Lock Knob (#38) into the hole on the Leg Developer Holder.
- D.) Attach the Main Seat Support (#4) to the Upper Cross Brace (#5). Secure it with two M10 x 2 3/4" Carriage Bolts (#59), one 5 1/2" x 2 3/4" Bracket (#31), two \varnothing 3/4" Washers (#61), and two M10 Aircraft Nuts (#63).

DIAGRAM 2

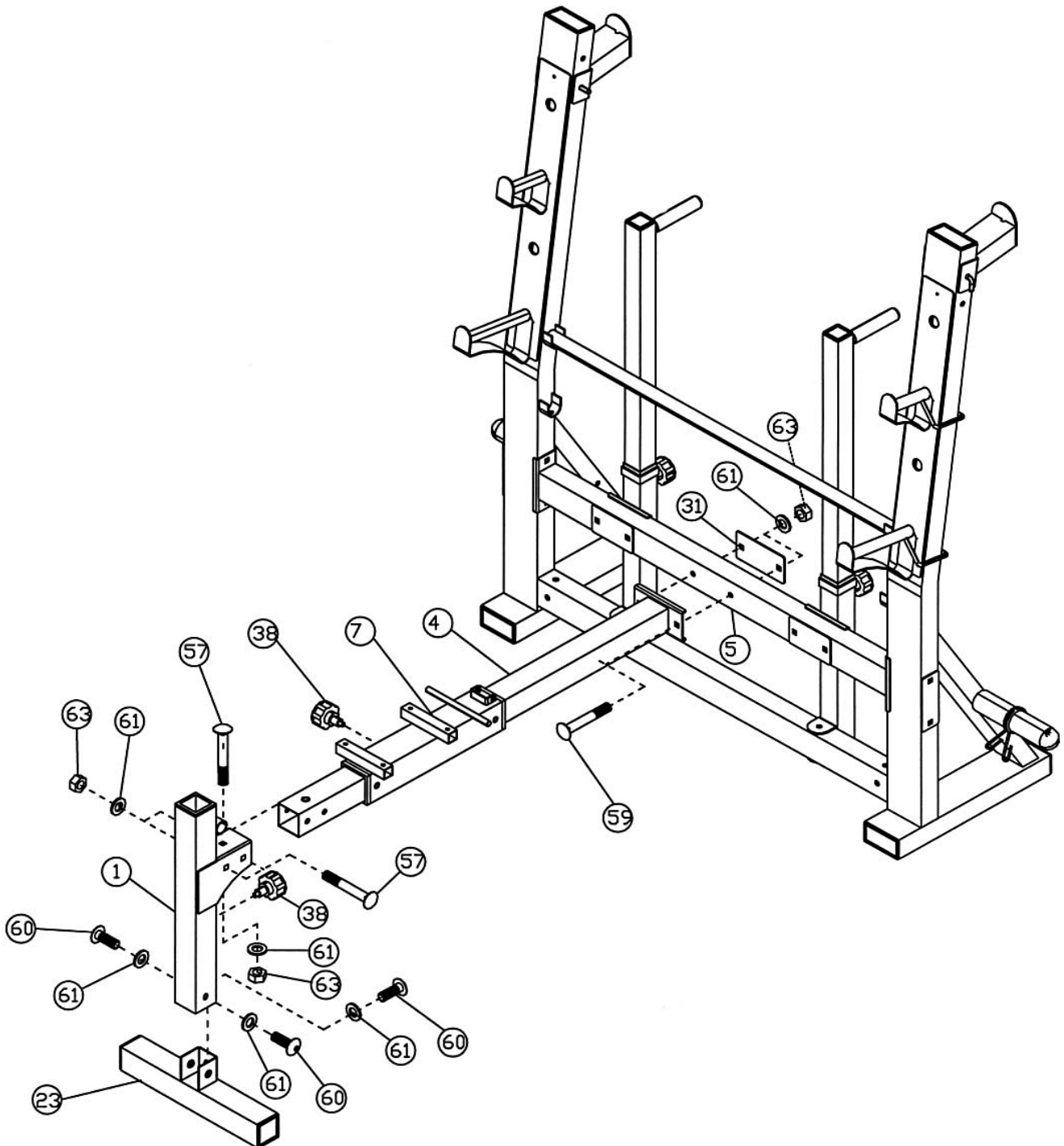

STEP 3 (See Diagram 3)

- A.) Attach the Backrest Incline Support (#14) to the holes in between the two Backrest Supports (#16). Attach the end of the Backrest Supports (#16) to the pivot on the Sliding Block (#7).
- B.) Attach the Backrest Board (#25) to the Backrest Supports. Secure it with four M8 x 1 5/8" Allen Bolts (#54) and Ø 5/8" Washers (#62).
- C.) When using the Dip Handles or doing the Squat exercises from the rear of the machine, lift up the Backrest Board to a near vertical position and secure the Incline Support (#14) to the open bracket on the Sliding Block (#7) with a 3" L-shaped Pin (#36). Please note the only purpose of the Backrest Incline Support, Bracket and Pin is to get the Backrest Board out of your way while doing exercise from the rear of the machine. They are not designed to support any weight or perform any exercise.
- D.) Place the Seat (#24) onto the Sliding Block (#7). Secure it with four M8 x 1 5/8" Allen Bolts (#54) and Ø 5/8" Washers (#62).

DIAGRAM 3

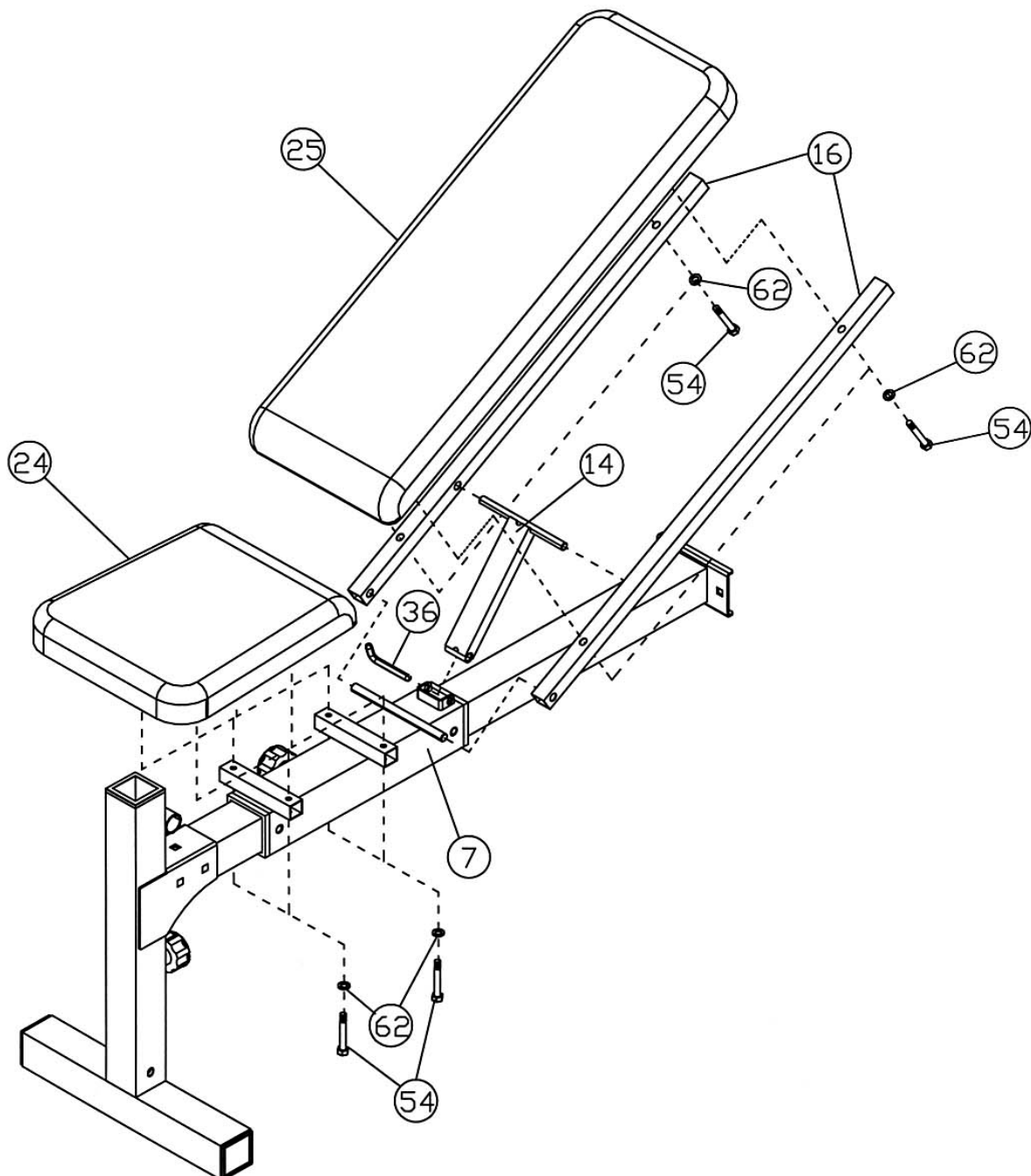

STEP 4 (See Diagram 4)

- A.) Attach the Leg Developer (#9) to the Leg Developer Holder (#1). Secure it with an Axle (#41), two M10 x 5/8" Allen Bolts (#60) and \varnothing 3/4" Washers (#61).
- B.) Insert one Foam Tube (#15) halfway through the hole on the Leg Developer Holder. Insert two Foam Tubes halfway through the holes on the Leg Developer. Push six Foam Rolls (#35) onto the Tubes from both ends. Plug six Foam Roll End Caps (#45) into the ends.
- C.) Slide an Olympic Sleeve (#39) to the weight post on the Leg Developer. Attach a Spring Clip (#40) to the Sleeve.
- D.) Attach the Arm Curl Pad (#26) to the Arm Curl Stand (#13). Secure it with two M8 x 5/8" Allen Bolts (#55) and \varnothing 5/8" Washers (#62).
- E.) Insert the Arm Curl Stand into the top opening on the Leg Developer Holder. Use the Lock Knob to hold the desired Arm Curl exercise position.
- F.) Attach the Curl Bar Handle Frame (#22) to the Leg Developer. Secure it with a 3" L-shaped Pin (#36). Remove the Arm Curl Stand and the Curl Bar Handle Frame when using the Leg Developer.
- G.) Insert a U-shaped Lock Pin (#70) through the slot on the Leg Developer Holder. Secure it with a Spring (#71), M6 x 1/2" Philips Screw (#67), and \varnothing 1/2" Spacer (#69). Pull the Pin out and drop the other end into the hole on the Leg Developer to lock it in place when using it for sit up exercise.

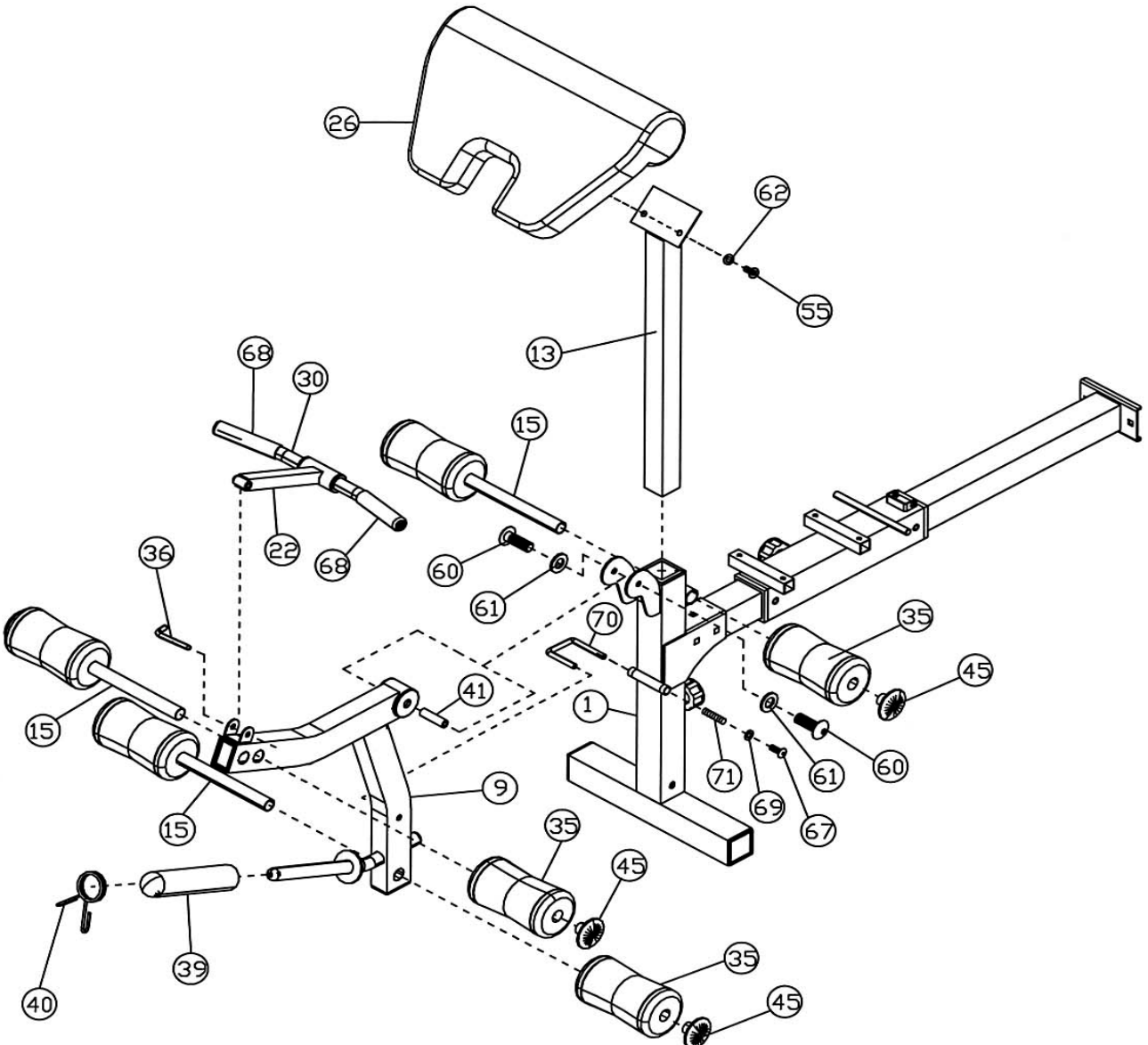

EXPLODED DIAGRAM

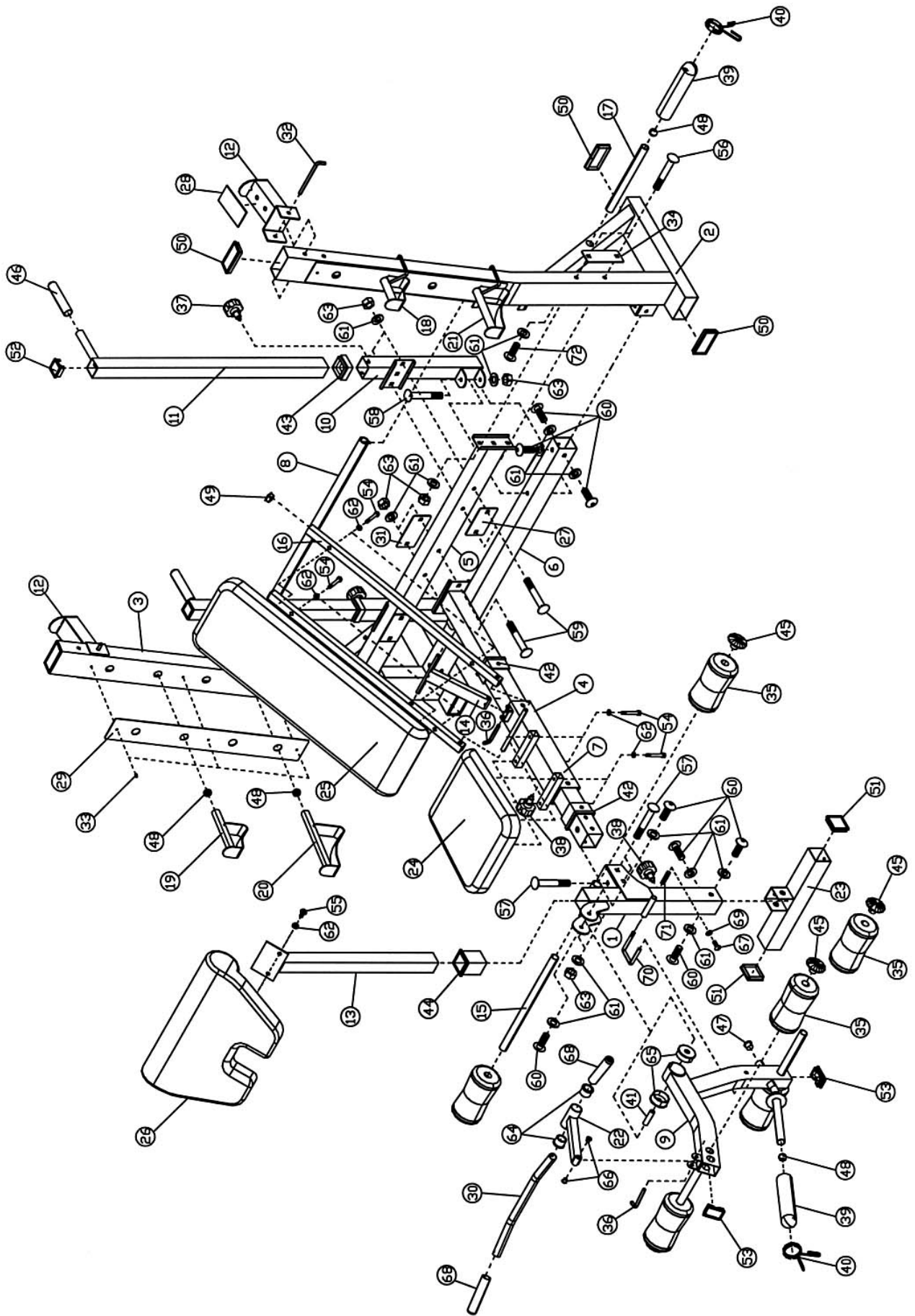

PARTS LIST

KEY NO. DESCRIPTION

Q'ty

KEY NO.	DESCRIPTION	Q'ty		Q'ty	
1	Leg Developer Holder	1	51	2 3/8" Square End Cap	2
2	Left Upright Beam	1	52	1 3/4" Square End Cap	2
3	Right Upright Beam	1	53	1 5/8" x 2 3/8" End Cap	2
4	Main Seat Support	1	54	M8 x 1 5/8" Allen Bolt	8
5	Upper Cross Brace	1	55	M8 x 5/8" Allen Bolt	2
6	Lower Cross Brace	1	56	M10 x 5 3/4" Carriage Bolt	4
7	Sliding Block	1	57	M10 x 3 1/8" Carriage Bolt	3
8	Backrest Adjustment Bar	1	58	M10 x 3 1/2" Carriage Bolt	2
9	Leg Developer	1	59	M10 x 2 3/4" Carriage Bolt	6
10	Dip Handle Base	2	60	M10 x 5/8" Allen Bolt	11
11	Dip Stand	2	61	Ø 3/4" Washer	28
12	Squat Bar Catch	2	62	Ø 5/8" Washer	10
13	Arm Curl Stand	1	63	M10 Aircraft Nut	15
14	Backrest Incline Support	1	64	Ø 1 1/2" Bushing	2
15	Foam Tube	3	65	Ø 2 3/8" Bushing	2
16	Backrest Support	2	66	Ø 3/4" Bushing	2
17	Weight Post	2	67	M6 x 1/2" Philips Screw	1
18	Left Bar Holder	1	68	Curl Handle Grip	2
19	Right Bar Holder	1	69	Ø 1/2" Spacer	1
20	Right Safety Catch	1	70	U-shaped Lock Pin	1
21	Left Safety Catch	1	71	Spring	1
22	Curl Bar Handle Frame	1	72	M10 x 3/4" Allen Bolt	2
23	Front Stabilizer	1		#4 Allen Wrench (Tool)	1
24	Seat	1		#5 Allen Wrench (Tool)	1
25	Backrest Board	1		#6 Allen Wrench (Tool)	2
26	Arm Curl Pad	1			
27	4 3/4" x 2 3/4" Bracket	2			
28	Rubber Bumper	2			
29	Chrome Panel	2			
30	Curl Bar Handle	1			
31	5 1/2" x 2 3/4" Bracket	1			
32	5 3/4" L-shaped Pin	2			
33	Chrome Panel Screw	6			
34	5 1/2" x 2" Bracket	2			
35	Foam Roll	6			
36	3" L-shaped Pin	2			
37	M10 Lock Knob	2			
38	M12 Lock Knob	2			
39	Olympic Sleeve	3			
40	Spring Clip	3			
41	Axle	1			
42	3" Sleeve	2			
43	2" Sleeve	2			
44	2 3/8" Sleeve	1			
45	Foam Roll End Cap	6			
46	Grip	2			
47	Ø 1" End Cap	1			
48	Ø 1" Cone-shaped End Cap	7			
49	1" Square End Cap	2			
50	4" x 2" End Cap	6			

IMPEX INC.

LIMITED WARRANTY

IMPEX Inc. ("IMPEX") warrants this product to be free from defects in workmanship and material, under normal use and service conditions, for a period of two years on the Frame from the date of purchase. This warranty extends only to the original purchaser. IMPEX's obligation under this Warranty is limited to replacing or repairing, at IMPEX's option.

All returns must be pre-authorized by IMPEX. Pre-authorization may be obtained by calling IMPEX Customer Service Department at 1-800-999-8899. All freights on products returned to IMPEX must be prepaid by the customer. This warranty does not extend to any product or damage to a product caused by or attributable to freight damage, abuse, misuse, improper or abnormal usage or repairs not provided by an IMPEX authorized service center or for products used for commercial or rental purposes. No other warranty beyond that specifically set forth above is authorized by IMPEX.

IMPEX is not responsible or liable for indirect, special or consequential damages arising out of or in connection with the use or performance of the product or other damages with respect to any economic loss, loss of property, loss of revenues or profits, loss of enjoyments or use, costs of removal, installation or other consequential damages or whatsoever natures. Some states do not allow the exclusion or limitation of incidental or consequential damages. Accordingly, the above limitation may not apply to you.

The warranty extended hereunder is in lieu of any and all other warranties and any implied warranties of merchantability or fitness for a particular purpose is limited in its scope and duration to the terms set forth herein. Some states do not allow limitations on how long an implied warranty lasts. Accordingly, the above limitation may not apply to you.

This warranty gives you specific legal right. You may also have other rights which vary from state to state. **Register on-line at www.impex-fitness.com**

**IMPEX INC.
14777 Don Julian
City of Industry, CA 91746**

ORDERING REPLACEMENT PARTS

Replacement parts can be ordered by calling our Customer Service Department toll-free at **1-800-999-8899** during our regular business hours: Monday through Friday, 9 am until 5 pm Pacific standard time.

info@impex-fitness.com

When ordering replacement parts, always give the following information.

1. Model
2. Description of Parts
3. Part Number
4. Date of Purchase